

1
WARRANTY

ForK

PALLET LIFT FORK

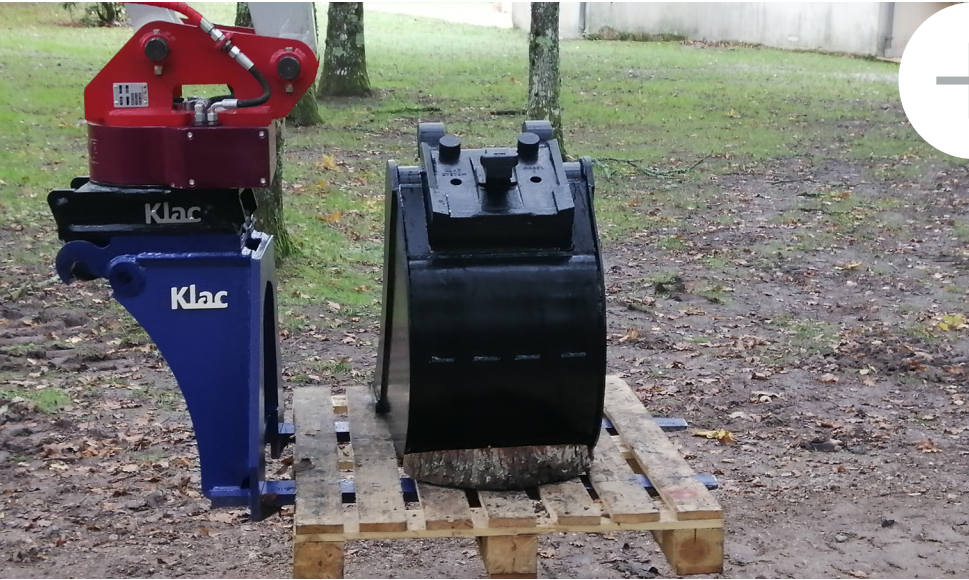

- Compact, innovative, modern concept
- Rugged and durable

A TOUCH OF MODERNITY

In fixed versions, the Klac pallet fork has an ingenious design for better visibility and handling.

The forged and tempered forks guarantee strength and longevity.

TECHNICAL FEATURES

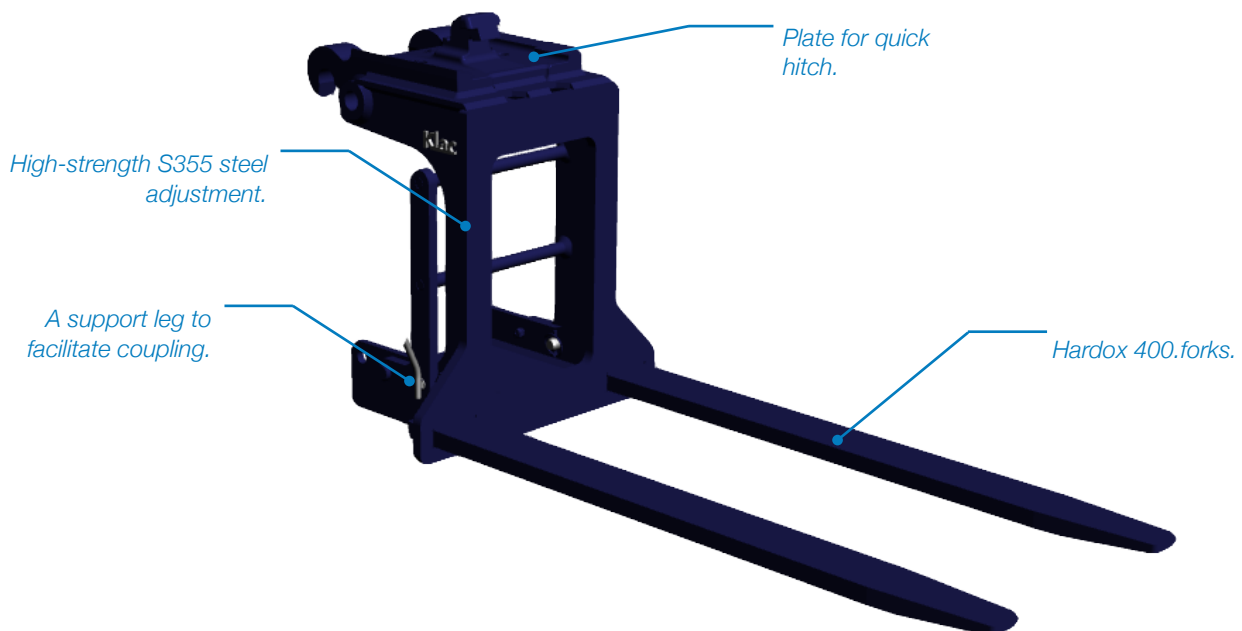



FOCUS ON
The fixe version



Product also designed to be used with the rotating coupler: holds the load in a horizontal position.

Equipped with a detachable support to facilitate coupling and uncoupling.



SAFETY QUESTION

Reinforced forks made from Hardox 400. Withstands the heaviest loads and ensures maximum durability.

 A coupling support that makes it easier to connect the coupler to the pallet lifter, reducing the risk of errors and ensuring safer handling.

Wide deck and rear counterweight ensure optimal load stability, prevent the pallet lifter from tipping over during attachment and significantly reduce the risk of the attachment falling.

AVAILABLE WITH



KLAC SYSTEM



KLAC +



ALTERNATIK



THE RANGE FORK pallet lift fork

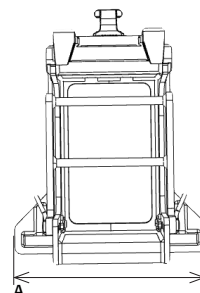
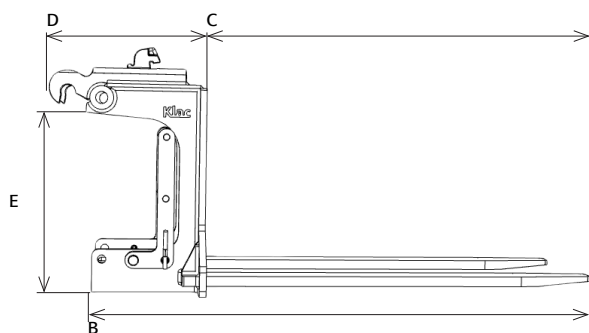

Weight	Load	A	B	C	D	E	Forks	
kg	kg	mm	mm	mm	mm	mm	(width/thickness)	
Model D / 1 (Mxs of 2 to 3,5t)	162	800	600	1 530	1 190	434	550	100/30
Model E / 2 (Mxs of 3 to 5t)	173	1 000	600	1 530	1 190	448	550	100/30
Model F / 3 (Mxs of 6 to 9t)	201	1 500	600	1 530	1 190	472	542	100/30

Model G
(Mxs of 9 to 12t)

On request

To use this accessory, your machine must be fitted with safety valves on the digging cylinder.



Klac industrie

Klac industrie S.A.
288, rue des Saules
Z.A Orléans Sologne
Saint-Cyr-En-Val
45075 Orléans
Cedex 2 France

Tél. (33) 2 38 49 82 82
Fax (33) 2 38 49 82 83

contact@klac-industrie.com

www.klac-industrie.com