

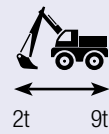

Klaci system

HYDRAULIC



2
GUARANTEE



PATENTED

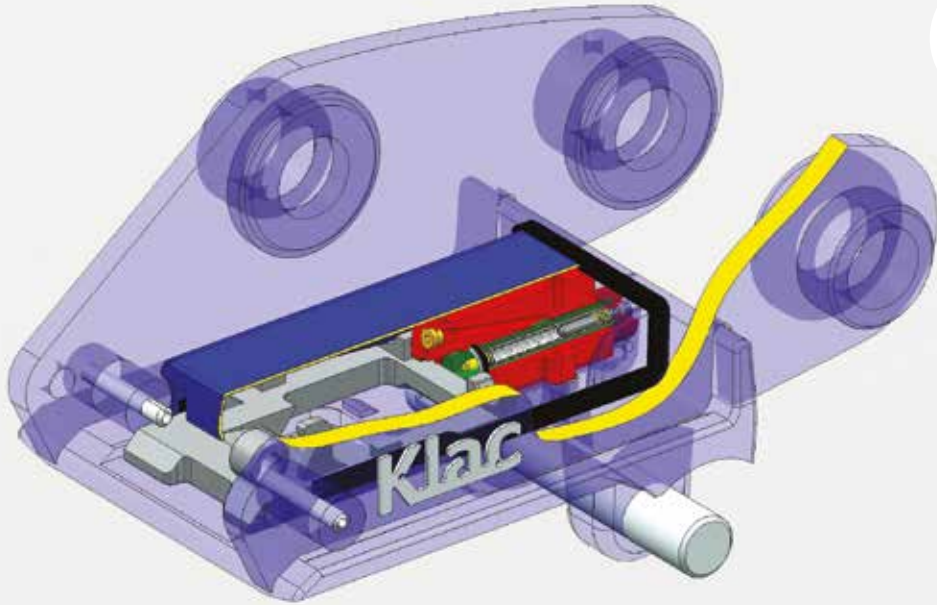

- Change the buckets without getting out of the cabin
- Mechanical and automatic locking, manual unlocking remains possible if needed
- A simple effect hydraulic line for unlocking
- Follows the original manufacturer's geometry
- Cast steel parts guaranteeing longevity and ruggedness
- Compliance with EC standards

AS SIMPLE AS THE MECHANICAL ONE

Quick coupler still simple and very compact, with permanent adjusting.

Hydraulic pressure is only for the release: no risk of accident due to an oil leak.

TECHNICAL FEATURES

Locking plate with 2 safety latches (Klaci serenity, patented system)

Single-acting cylinder, pushing the plate for unlocking

Body of the quick coupler made of cast steel

Thanks to the built-in rings, handling is safe and efficient

2 engagement springs

Unlocking key

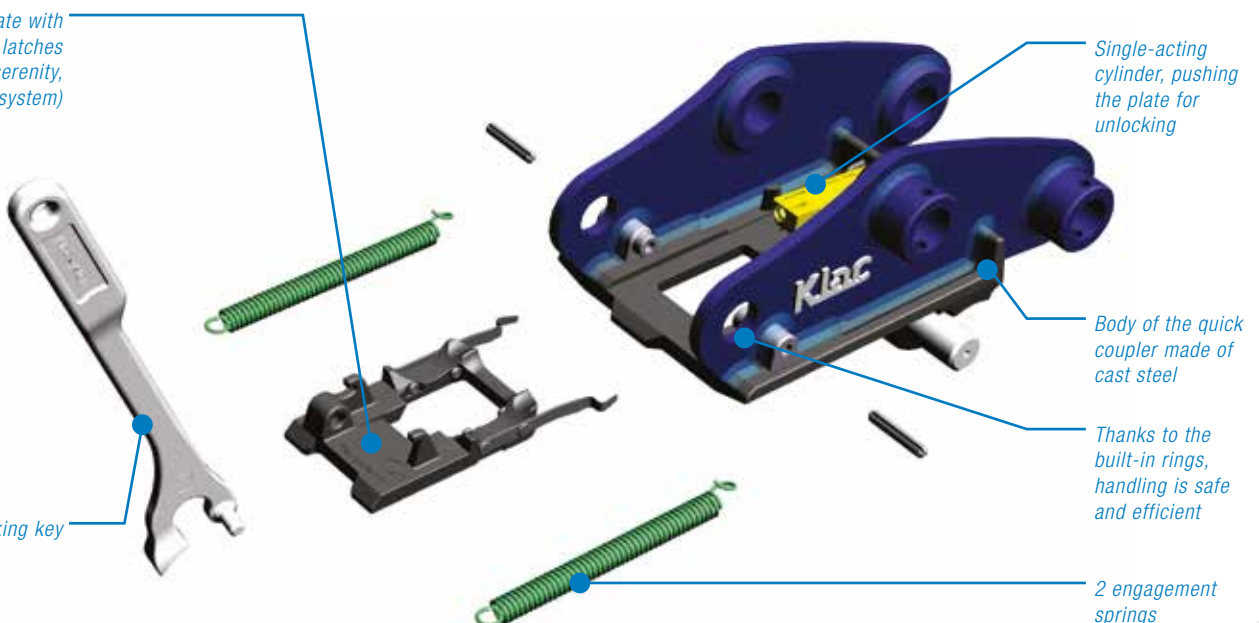

FOCUS ON Klac protect

Connecting hydraulic attachments is always problematic: the hose loop generated is difficult to control, the hose is located in a risk area, and the implementation is difficult in the end balance.

With **Klac protect**, the loop is contained in a box. It is thus controlled and protected, irrespective of the position of the quick coupler, throughout its movements.



Klac control

The case that triggers the release and provides continuous control of the lock (visual and audible warning).



The hydraulic installation

Hydraulic **Klac system** requires **200 to 250 bars** for proper operation. The seals of the cylinder and the hose **Klac protect** can operate up to pressures of **350 bar maximum**, so it is not necessary to install a pressure limiter other than the one of the machine.

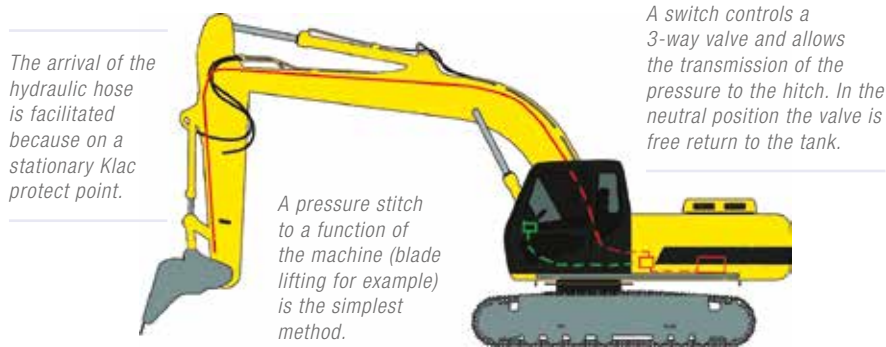

A free return to the tank is recommended (in any case max 2 bars counter pressure).



(HYDRAULIC) Klac system RANGE

	Width (mm)	Coupler's weight* (kg)	Kit's weight (kg)
Model C (1 to 2t)	nd	nd	5
Model D (2 to 3,5t)	230	26	9
Model E (3,5 to 5,5t)	270	45	14
Model F (5,5 to 9t)	310	75	24

*depending on coupler



ABOUT SAFETY

THE EUROPEAN STANDARD EN474-1

Amended in 2013 now imposes specific requirements for engagement system and locking system.

 **Klac system hydraulic** has the same trigger system (springs) and locking system (latches) as the mechanical version.

The proper functioning of the hydraulic controls is indicated in the cabin. The hydraulic pressure is not required to maintain the locking.

The coupler remains locked at all the times.



Klac industrie

Klac industrie SAS

288, rue des Saules
ZA La Saussaye (St Cyr en Val)
45075 Orléans - Cedex 2
France

Tel. (33) 2 38 49 82 82
Fax (33) 2 38 49 82 83

contact@klac-industrie.com

www.klac-industrie.com