

**1**  
WARRANTY

**NEW**

# Kutter

## HEDGE TRIMMER



- Available in 3 working widths: 1,200, 1,600 or 1,800 mm
- Cuts up to 3 cm in diameter
- Clean, fast and precise cutting
- Blades and fingers are replaceable
- No external drainage

### THE STRAIGHT CUT !

A **hedge trimmer** allows you to cut any tree, bush or branch up to 3 centimetres in diameter. Ideal for maintaining and rehabilitate your garden, driveways, roads, etc. Its rotating joint (see option) gives the advantage of being used in both way, horizontally and vertically.

### TECHNICAL FEATURES

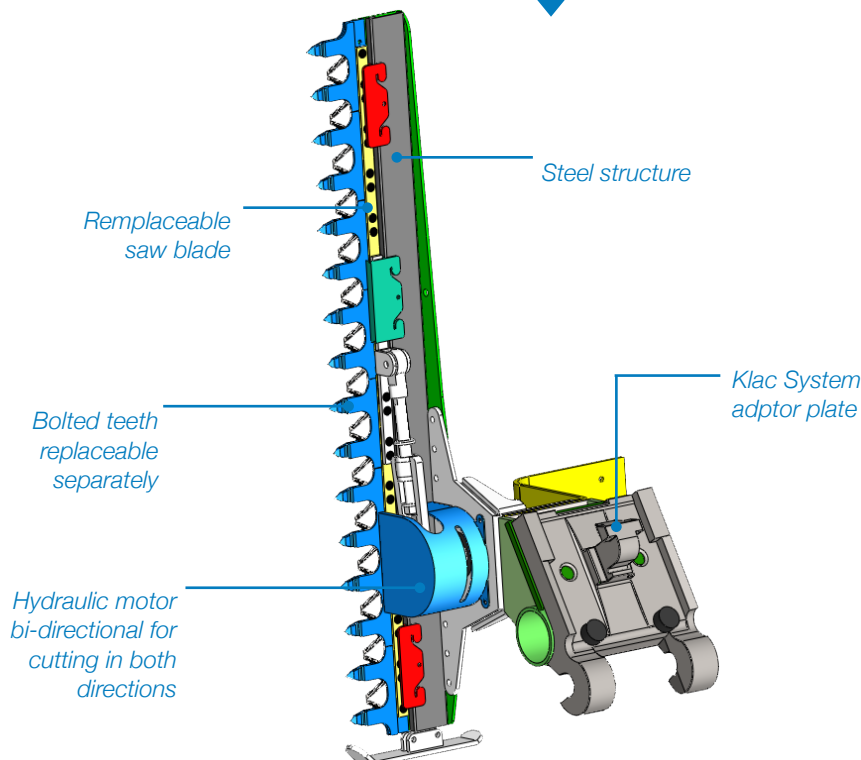

3 possible versions:

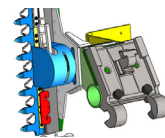

**STANDARD**

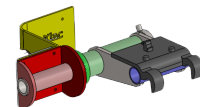

**SOLO**

Vertical rotation

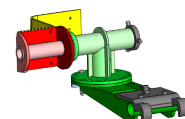

**DUO**

Horizontal & vertical rotation



## FOCUS ON Rotating joint

Choose your option at time of order:

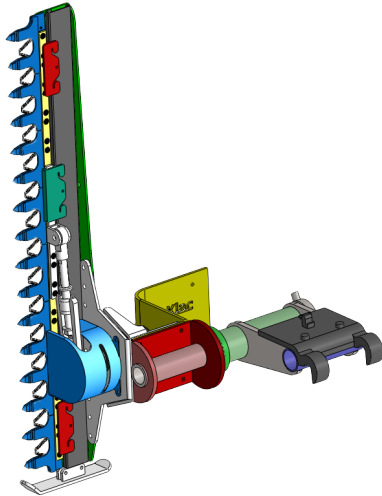

**SOLO**  
Rotary joint, vertical rotation

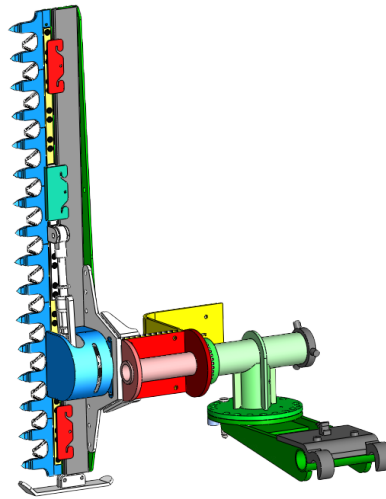

**DUO**  
Rotary joint, horizontal and vertical rotation



## SAFETY QUESTION

 The motor is protected by a cover. This prevents any interference with the machine's kinematics.

The Solo or Duo options allow a precise adjustment of the cutting position. This provides better control of the tool and reduces the risk of dangerous movements.

AVAILABLE WITH



**KLAC SYSTEM**



**ALTERNATIK**



## THE RANGE Hedge Trimmer **KUTTER**

	Reference	Weight kg	Pressure max bar	Max. flow l/min	Engine cylinder cc	Blade length mm
<b>Model C / 0</b> (Mxs of 0,8 to 2t)	YKTC1200**B	44/46	120	15	50	1 200
<b>Model D / 1</b> (Mxs of 2 to 3,5t)	YKTD1200**B	44/46	120	20	100	1 200
	YKTD1600**B	55/58	120	20	100	1 600
	YKTD1800**B	58/63	120	20	100	1 800
<b>Model E / 2</b> (Mxs of 3,5 to 5,5t)	YKTE1200**B	44/46	120	40	160	1 200
	YKTE1600**B	55/58	120	40	160	1 600
	YKTE1800**B	58/63	120	40	160	1 800
<b>Model F / 3</b> (Mxs of 5,5 to 8t)	On request					

Choice of blade position

\*R = right blade

\*L = left blade

Options

\*S = SOLO vertical rotation

\*D = DUO horizontal & vertical rotation

The blade position and the different options can only be selected at time of order. It is not possible to change these after the order has been placed.



**Klac industrie**

**Klac industrie S.A.**  
288, rue des Saules  
Z.A Orléans Sologne  
Saint-Cyr-En-Val  
45075 Orléans  
Cedex 2 France

Tél. (33) 2 38 49 82 82  
Fax (33) 2 38 49 82 83

contact@klac-industrie.com

www.klac-industrie.com